

## MR-250MF Multi-Function Machine Room Station

The Multi-Function Machine Room Phone offers full flexibility for an elevator installation.

### Features

- Phone out (for tech support)
- Phone in (from outside the complex)
- Call any elevator connected to the LS-250 System
- Call any other machine room (MR-250MF)
- Call the Lobby Rescue Station
- Call the security offices (any Remote Station)
- Call any machine room from the lobby or security office
- No limit to the number of MR-250MF's (subject to the max 80 elevator phones + machine room phones)



MR-250MF

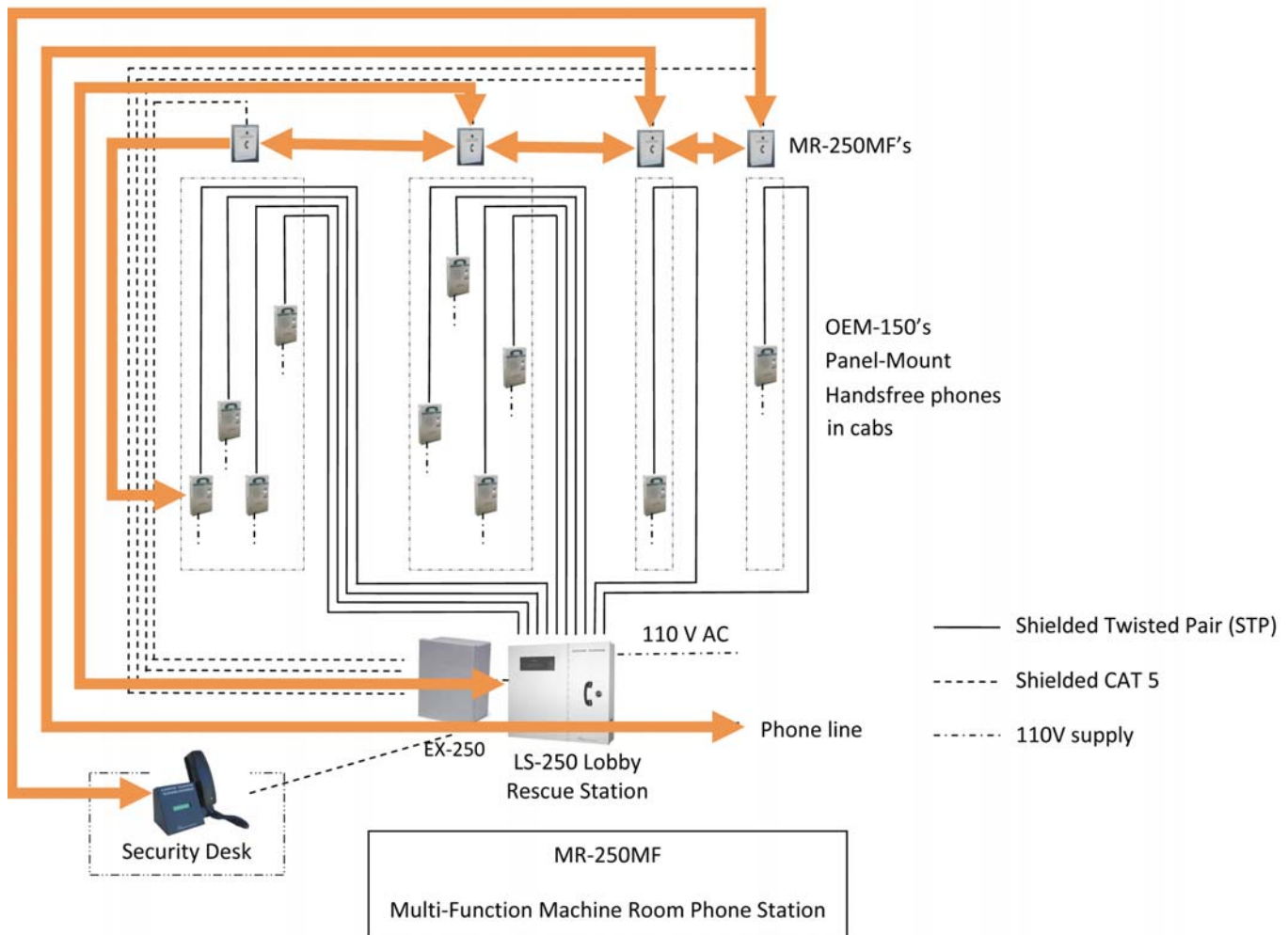

## MR-250MF Multi-Function Machine Room Station

### Calling out:

The MR-250MF enables calls into every elevator phone, the Lobby Rescue Station and the CACF and Security Desk if all are connected to the LS-250 Rescue Station System, as well as every other machine and control room equipped with an MR-250MF. Calls can also be made out of the building if a regular Telco line is connected to the Rescue Station.

### Calling in:

Calls can be made into any MR-250MF (in the same way one calls into an elevator) from outside or from the Lobby Rescue Station, the CACF or a security desk.

### SPECIFICATIONS

<b>Certification:</b>	Handset is FCC / Industry Canada / CSA approved.
<b>Wiring:</b>	CAT-5 communication cable between the machine room and LS-250 Rescue Station. Four conductors (two twisted pairs) are required, preferably shielded.
<b>Connections:</b>	Two pairs of screw connectors for the outside wiring.
<b>Mounting:</b>	Surface mount on wall of machine room or on side of controller. D-knockout on door for lock assembly if required.
<b>Dimensions:</b>	12.5" high x 8" wide x 3.5" deep.
<b>Finish:</b>	White powder coated 16 gauge steel. Black silk-screen lettering at the top of the unit saying "Elevator Telephone / Téléphone D'Ascenseur".
<b>Weight:</b>	6.6 lbs. (3 kg).

*Design and specification may change without notice.*



**Canada:** Head Office: 4427 Dawson Street, Burnaby BC V5C 4B8 • Tel: 604.502.9007 • Fax: 604.502.9044  
Vancouver BC, Calgary AB, Edmonton AB, Toronto ON, Montreal QC

**USA:** Bellingham WA

**Toll Free:** 1-877-731-1010 • **Inquiries:** info@webbelectronicinc.com • **Website:** webbelectronicinc.com